

B-B

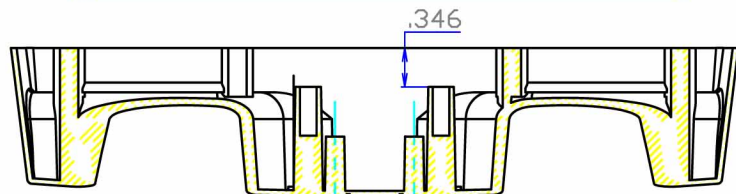
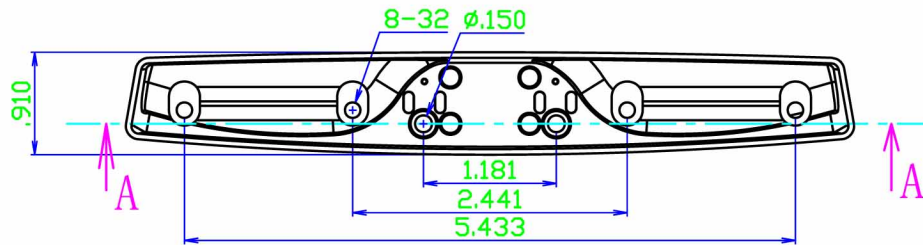
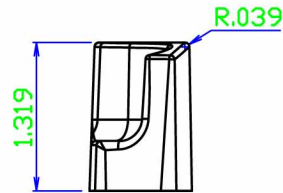
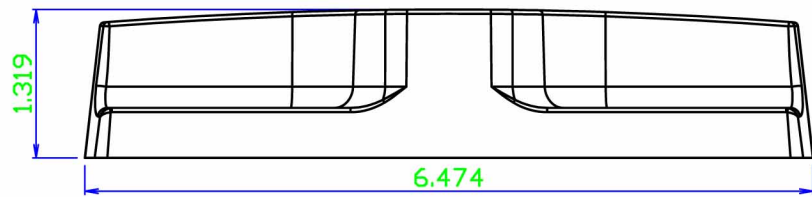
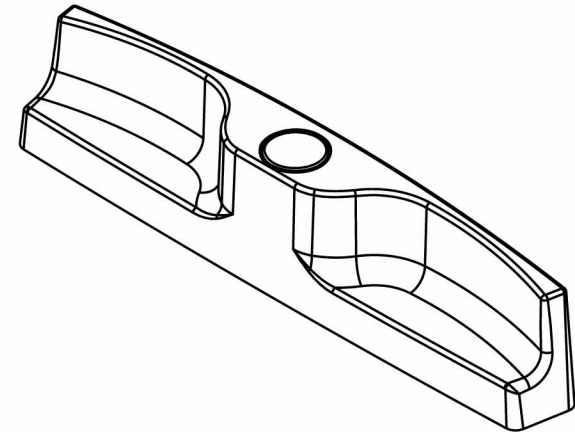

A-A

STANDARD TOLERANCES
(UNLESS OTHERWISE NOTED)
ALL WALLS = ±.005
.000 TO .499 = ±.005
.500 TO 4.000 = ±.010
OVER 4.000 = ±0.015
ANGULAR DIM = ±1/2°

Itemref	Quantity	Material: Zinc Alloy			Article No./Reference	
Designed by JZ	Checked by JG	Approved by - date -	File name -	Date 2006.06.14	Scale 1:1	
TKG COMPONENTS LLC				Pull handle		
				0166	Edition 1	Sheet 1/1