

RevNo	Revision note	Date	Signature	Checked
-------	---------------	------	-----------	---------

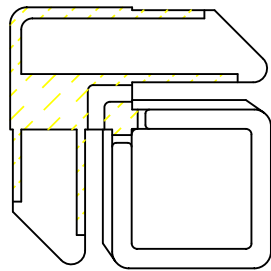

SECTION A-A

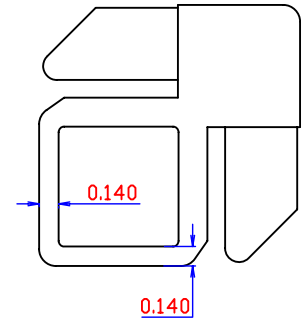
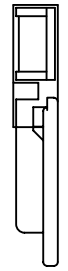
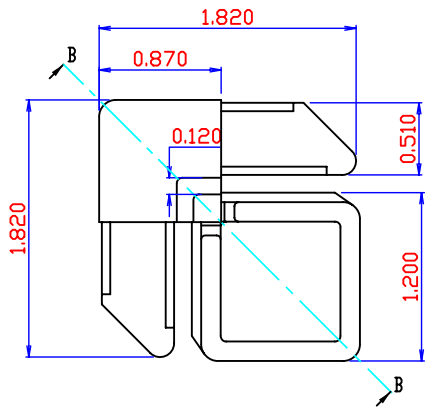
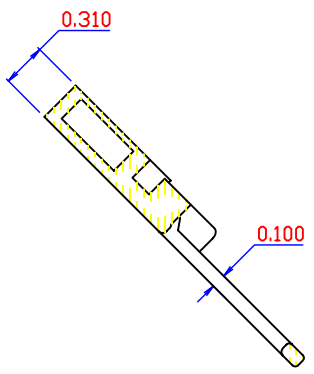

SECTION B-B

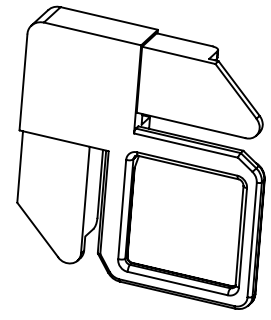
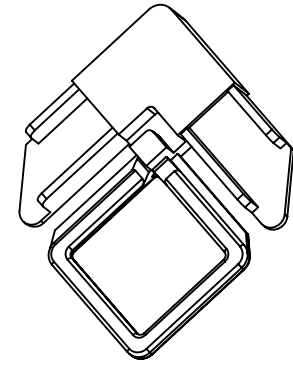

0031

<b>STANDARD TOLERANCES (UNLESS OTHERWISE NOTED)</b> ALL WALLS =±.005 .000 TO .499 =±.005 .500 TO 4.000 =±.010 OVER 4.000 =±0.015 ANGULAR DIM =±1/2°	Itemref	Quantity	Material: ABS		Article No./Reference		
	Designed by JZ	Checked by JG	Approved by - date -	File name -	Date 2004.06.30	Scale 1:1	
	TKG COMPONENTS LLC				REGULAR SCREEN CORNER		
					#0031	Edition 1	Sheet 1/1