

A
B
C
D
E
F

A
B
C
D
E
F

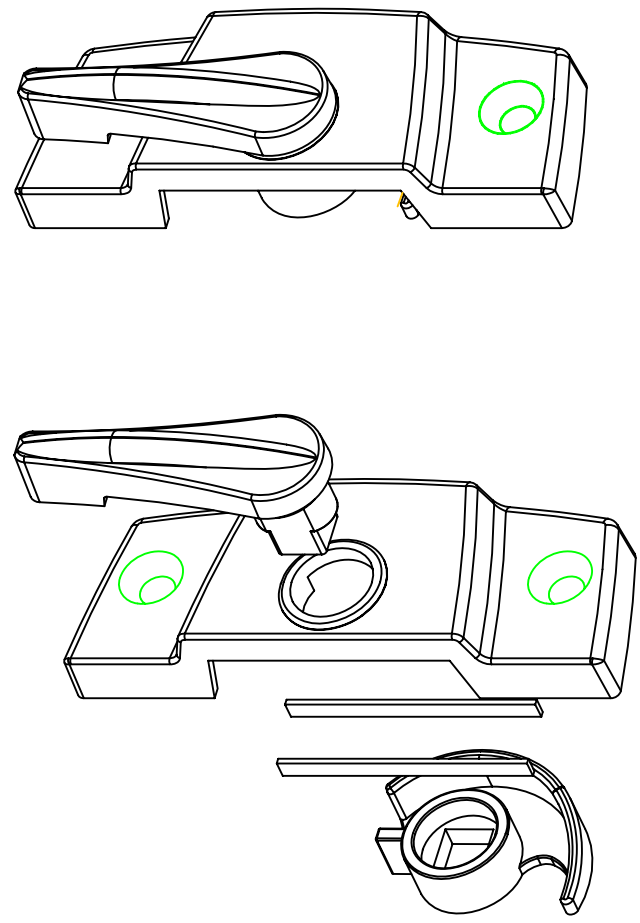
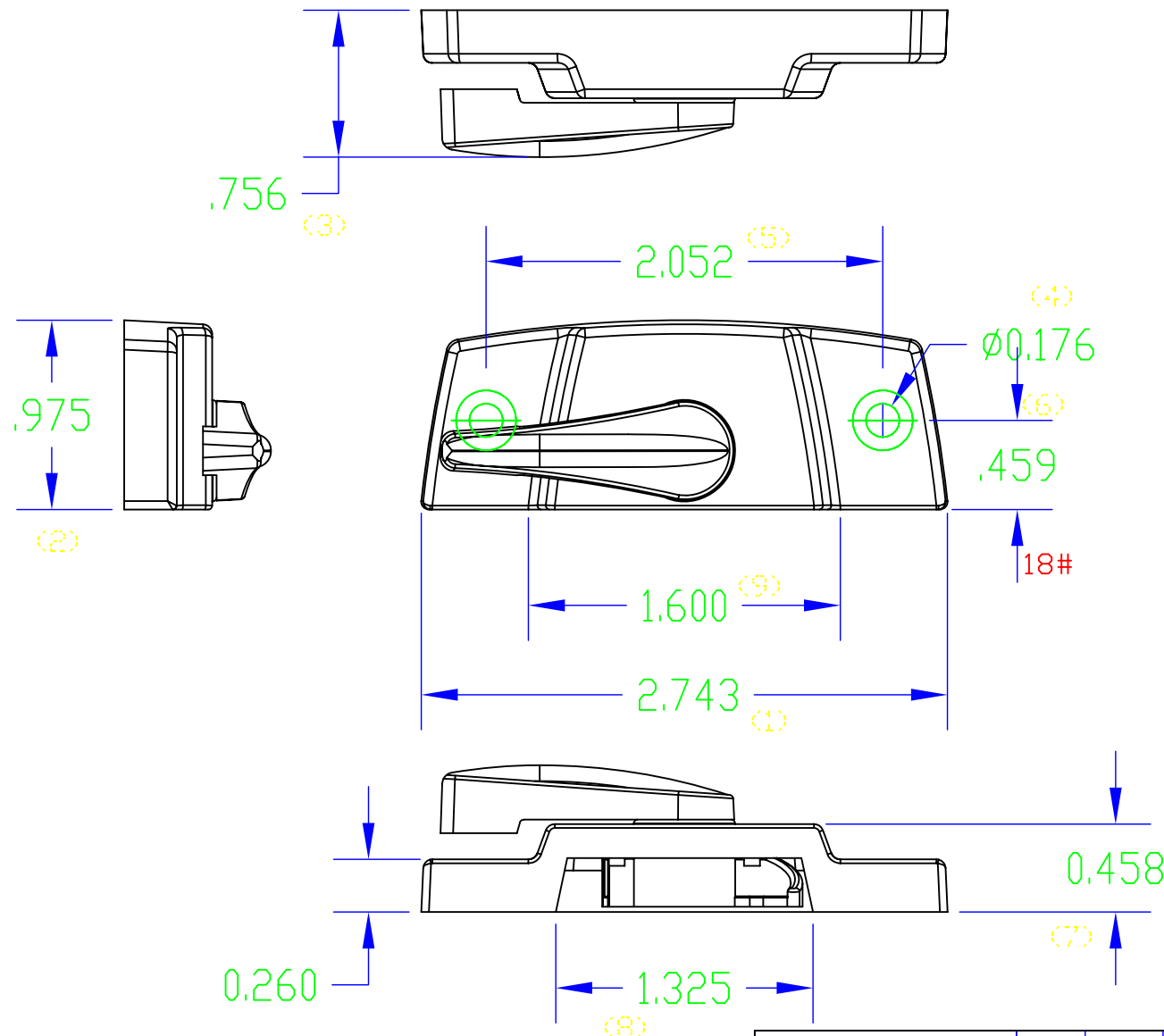

#18 SASH LOCK-HOLES CLOSE TO CAM

STANDARD TOLERANCES
(UNLESS OTHERWISE NOTED)
ALL WALLS =±.005
.000 TO .499 =±.005
.500 TO 4.000 =±.010
OVER 4.000 =±0.015
ANGULAR DIM =±1/2°

Itemref	Quantity	Material: ZINC ALLOY			Article No./Reference	
Designed by JZ	Checked by JG	Approved by - date -	File name -	Date 2004.07.01	Scale 1:1	
TKG COMPONENTS LLC				SASH LOCK-HOLES FARTHEST FROM CAM		
				0018	Edition -	Sheet A3